



US 20070157402A1

(19) **United States**

(12) **Patent Application Publication**
Caffarella

(10) **Pub. No.: US 2007/0157402 A1**

(43) **Pub. Date: Jul. 12, 2007**

(54) **IONIZED AIR BLOWER**

Publication Classification

(75) Inventor: **Thomas E. Caffarella**, Grand Island,
NY (US)

(51) **Int. Cl.**
A47L 13/40 (2006.01)

(52) **U.S. Cl.** 15/1.51

Correspondence Address:
DAYCO PRODUCTS, LLC
1 PRESTIGE PLACE
MIAMISBURG, OH 45342 (US)

(57) **ABSTRACT**

(73) Assignee: **NRD LLC**

An ionized air blower is disclosed for simultaneously neutralizing static charge and dislodging particulate matter, such as dust, from a surface to be cleaned. The ionized air blower comprises a compressible air chamber, such as a resilient bulb, and an ionizer. The ionizer ionizes air molecules expelled from the chamber to provide a stream of ionized air.

(21) Appl. No.: **11/331,294**

(22) Filed: **Jan. 12, 2006**

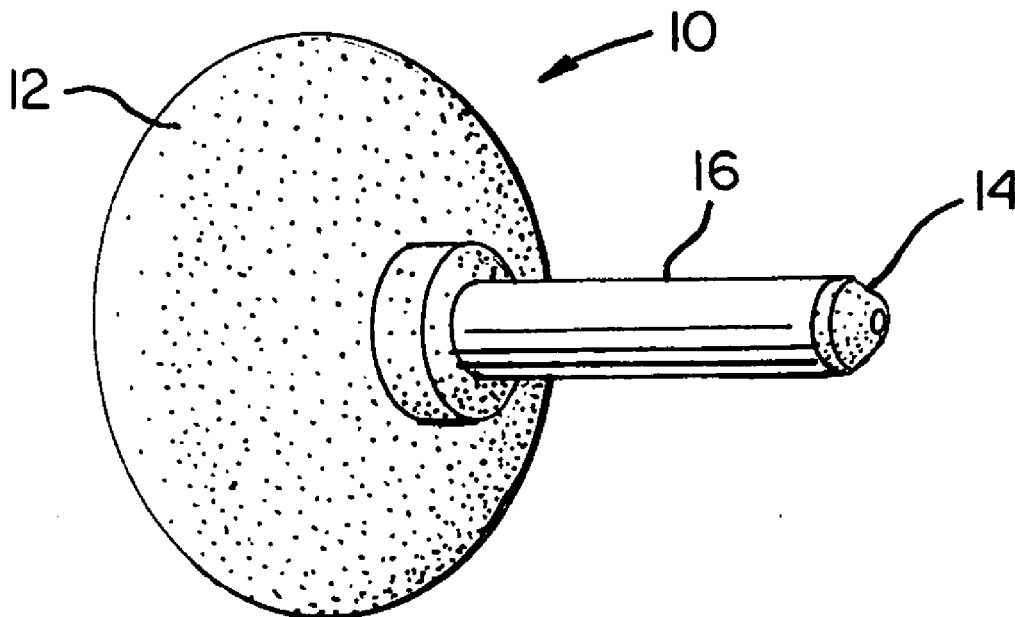

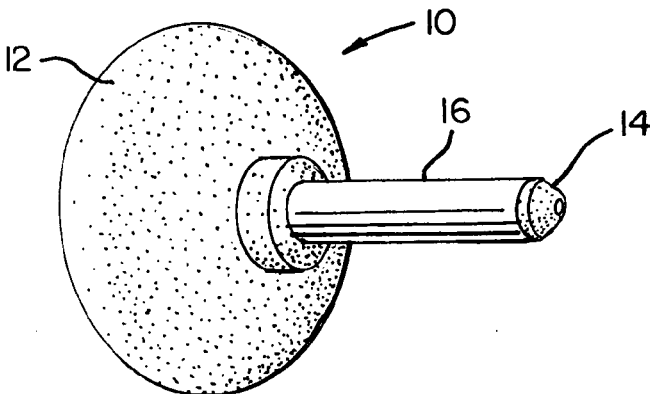

FIG. 1

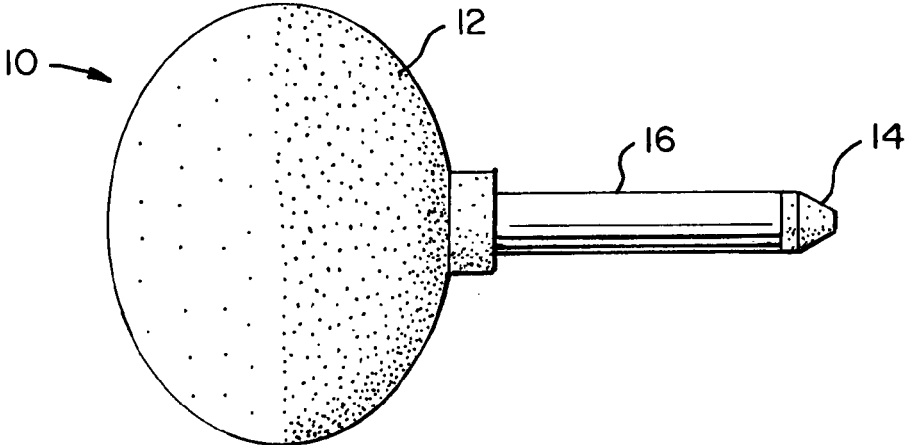

FIG. 2

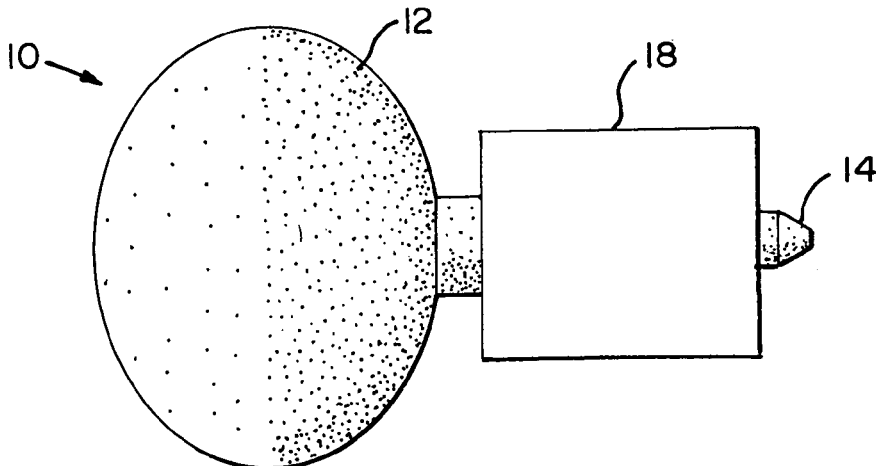

FIG. 3

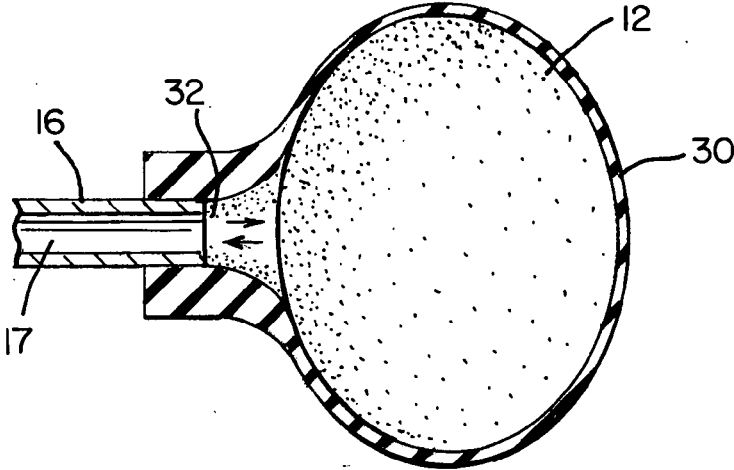

FIG. 4

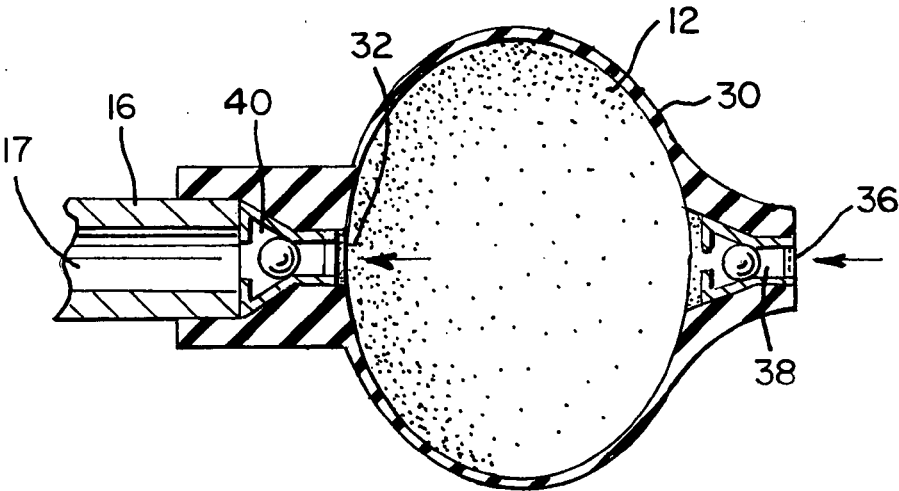

FIG. 5

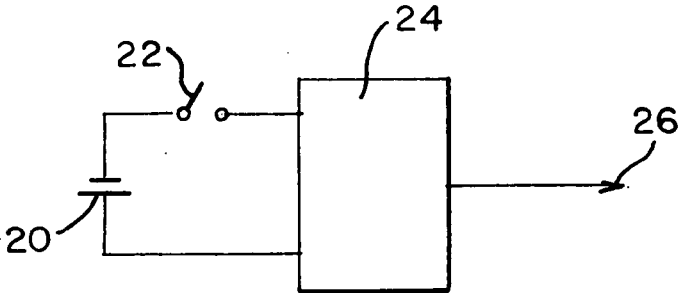

FIG. 6

IONIZED AIR BLOWER

TECHNICAL FIELD

[0001] The present invention is directed to static eliminators and more particularly to an ionized air blower for neutralizing and removing statically charged particles from a surface to be cleaned.

BACKGROUND

[0002] Static is the accumulation of electrical charges on the surface of a non-conductive material. Static can be produced when two different non-conducting materials are rubbed together. It is well known that static charge may cause unwanted dust particles to be attracted and held to a surface such as a camera lens or a digital imaging sensor.

[0003] Attempts to merely blow dust off of a statically charged surface is a temporary solution at best. Because the static charge remains, additional dust particles will be attracted and held to the surface. Moreover, attempts to wipe or brush dust from a statically charged surface may aggravate the problem by increasing the static charge on the surface.

[0004] Numerous methods and devices have been developed to reduce or eliminate static charge. One such method uses ionized air to neutralize static charge on a surface or the dust particles attracted to the surface. Devices for producing ionized air are well known and include high voltage electronic devices that use a corona discharge and radioactive devices that emit alpha particles. It is also known to use these devices in combination with electric fans or compressed air sources to direct the ionized air at the surface to be cleaned. Several examples of known ionizers are disclosed in U.S. Pat. Nos. 1,731,030, 3,156,847, 3,179,849, 4,258,408, 4,333,123, 4,438,479, 4,665,462, 5,095,400, 5,388,769, 5,508,880, 6,118,645, 6,373,680, 6,739,530 and 6,850,403 and U.S. Pat. Publication No. 2004/0118428.

[0005] Known ionizers that use "shop air" from a feed line attached to a pump or compressed air tank suffer from lack of mobility. Ionizers that utilize an electric fan or pump are often heavy or bulky and require access to a power source or batteries. Likewise, ionizers that use canned compressed air, although mobile, are expensive due to the cost of replacement air cans.

[0006] Therefore, a new ionized air blower is desired that is lightweight, mobile and does not require a separate air source.

SUMMARY

[0007] According to a first aspect an ionized air blower is provided comprising a compressible air chamber and an ionizer. When the chamber is compressed, a stream of air is produced through an exhaust opening in the chamber. The ionizer, which may be any conventional ionizer known in the art, ionizes air molecules passing through the exhaust opening to provide a stream of ionized air.

[0008] According to a second aspect an ionized air blower is provided comprising a hand-compressible resilient bulb for producing a stream of air when compressed and an ionizer for ionizing air molecules passing through an exhaust opening in the bulb.

[0009] According to a third aspect an ionized air blower is provided comprising a hand-compressible resilient bulb for producing a stream of air when the bulb is compressed and a tubular nuclear ionizer for ionizing air molecules that pass out of the bulb and through the ionizer.

BRIEF DESCRIPTION OF THE DRAWINGS

[0010] FIG. 1 is a perspective view of an ionized air blower according to one embodiment;

[0011] FIG. 2 is a plan view of the ionized air blower of FIG. 1;

[0012] FIG. 3 is a plan view of an ionized air blower according to a second embodiment;

[0013] FIG. 4 is a partial cross-section view of an ionized air blower depicting a bulb according to one embodiment for use with the ionized air blowers of FIGS. 2 or 3;

[0014] FIG. 5 is a partial cross-section view of an ionized air blower depicting a bulb according to a second embodiment for use with the ionized air blowers of FIGS. 2 or 3;

[0015] FIG. 6 is a schematic circuit diagram of a typical electric corona discharge ionizer suitable for use in the ionized air blower of FIG. 3.

DETAILED DESCRIPTION

[0016] An ionized air blower **10** is disclosed for removing dust and neutralizing static charge on a surface to be cleaned. The ionized air blower **10** comprises a compressible air chamber **12** and an energy source or ionizer for ionizing air molecules. When compressed or squeezed, the chamber **12** produces a stream of air with moderate velocity at essentially ambient pressure. The air stream passes through, over or across the ionizer to pick up ionized air molecules. A nozzle **14** may be provided for directing the ionized air at a surface to be cleaned.

[0017] Referring to FIGS. 1 and 2, the energy source may be a nuclear ionizer **16**, the basic features of which are known in the art. Examples of known nuclear ionizers are disclosed in U.S. Pat. Nos. 4,438,479 and 6,739,530, which are incorporated herein by reference. Typically, the energy source in a nuclear ionizer comprises an alpha particle emitting metal foil, such as polonium. Referring now to FIGS. 4 and 5, the foil may be positioned within an air path **17** through the ionizer or along a wall of the air path **17**.

[0018] Alternatively, referring to FIG. 3, the energy source may be a high voltage electric ionizer **18**, the basic structure of which is known in the art. Examples of known electric ionizers are disclosed in U.S. Pat. Nos. 3,156,847, 3,179,849, 4,333,123 and 5,388,769, which are incorporated herein by reference. Referring to FIG. 6, the basic block diagram of a typical electric ionizer comprises a battery **20**, a switch **22**, a high voltage power supply **24** and one or more corona discharge points **26**. The corona discharge point **26** may be positioned such that the stream of air produced by compression of the chamber **12** passes across the point **26**.

[0019] Referring to FIGS. 1-5, the chamber **12** may comprise a hand-compressible resilient bulb. The bulb provides the advantage of being a light-weight, compact, self-contained and therefore easily transportable source of air for the ionized air blower. Unlike conventional anti-static guns, the

ionized air blowers of FIGS. 1-5 do not need to be connected to an external air source such as shop air or a compressed air can. Alternatively, the chamber 12 may comprise bellows or other hand pump devices.

[0020] Referring to FIG. 4, the compressible chamber 12 may comprise a side wall 30 and an exhaust opening 32. The side wall 30 may be made of synthetic rubber or similar material that will allow a user to compress the chamber 12 by hand but which will also return to its original shape when released. The exhaust opening 32 may be coupled to the ionizer such that the exhaust opening 32 is in fluid communication with an air path 17 through the ionizer. In this configuration, compression or squeezing of the chamber 12 will cause a stream of air to pass through the exhaust opening 32 and the ionizer. The ionizer may be tubular and may comprise a nozzle 14 at its exit for directing ionized air.

[0021] In another embodiment, depicted in FIG. 5, the chamber 12 may include a valve arrangement to provide a desired air flow path through the ionizer. Still referring to FIG. 5, the chamber side wall 30 includes an entrance opening 36 opposite the exhaust opening 32 that includes a one-way air valve 38. The valve 38, which may be any typical one-way air valve, is oriented to permit air flow into, but not out of, the chamber 12. The exhaust opening 32 similarly includes a one-way air valve 40, which is oriented to permit air flow out of, but not into, the chamber 12. In this configuration, when the chamber is compressed, the valve 38 closes and the valve 40 in the exhaust opening opens to permit air to be pushed out of the chamber 12. When the chamber 12 is released and permitted to return to its original shape, valve 40 closes and valve 38 in the entrance opening 36 opens to permit air to refill the chamber 12. Thus, one-way flow through the chamber is achieved.

[0022] The ionized air blowers disclosed herein are designed to simultaneously neutralize static charge and dislodge particulate matter, such as dust, from a surface to be cleaned. Because the described ionized air blowers do not require a separate source of air, they are portable, reusable and less expensive over time than typical anti-static guns. They further provide the advantage of being lightweight, compact, and self-contained.

What is claimed is:

1. An ionized air blower comprising:
 - a compressible air chamber for producing a stream of air through an exhaust opening of the chamber when the chamber is compressed; and
 - an ionizer for ionizing air molecules passing through the exhaust opening.
2. The ionized air blower of claim 1 wherein the compressible air chamber comprises a resilient bulb.
3. The ionized air blower of claim 1 wherein the compressible air chamber is sized to fit within a user's hand.

4. The ionized air blower of claim 3 wherein the ionizer comprises a nuclear ionizer.

5. The ionized air blower of claim 3 wherein the ionizer comprises an electrical corona discharge ionizer.

6. The ionized air blower of claim 3 wherein the ionizer comprises a tubular nozzle in fluid communication with the exhaust opening.

7. The ionized air blower of claim 1 wherein the compressible air chamber further comprises an entrance opening comprising a one-way air valve that permits air to enter but substantially prevents air from exiting the chamber through the entrance opening.

8. The ionized air blower of claim 7 wherein the exhaust opening further comprises a one-way air valve that permits air to exit but substantially prevents air from entering the chamber through the exhaust opening.

9. An ionized air blower comprising:

- a hand-compressible resilient bulb for producing a stream of air through an exhaust opening of the bulb when the bulb is compressed; and

- an ionizer for ionizing air molecules passing through the exhaust opening.

10. The ionized air blower of claim 9 wherein the ionizer comprises an alpha particle emitting nuclear ionizer.

11. The ionized air blower of claim 9 wherein the ionizer comprises an electrical corona discharge ionizer.

12. The ionized air blower of claim 9 further comprising a tubular nozzle for directing the stream of air passing through the exhaust opening.

13. The ionized air blower of claim 9 wherein the compressible bulb further comprises an entrance opening comprising a one-way air valve that permits air to enter but substantially prevents air from exiting the bulb through the entrance opening.

14. The ionized air blower of claim 13 wherein the exhaust opening further comprises a one-way air valve that permits air to exit but substantially prevents air from entering the bulb through the exhaust opening.

15. An ionized air blower comprising:

- a hand-compressible resilient bulb for producing a stream of air through an exhaust opening of the bulb when the bulb is compressed; and

- a tubular nuclear ionizer comprising an air path in fluid communication with the exhaust opening.

16. The ionized air blower of claim 15 wherein the bulb further comprises first and second one-way air valves, the first air valve oriented to substantially prevent air from exiting the bulb, and the second air valve oriented at the exhaust opening to permit air to exit the bulb when the bulb is compressed.

* * * * *